

## Cyberhawk-300/MPC Installation Bulletin

Document No: 202-001615-601

Rev: A06

### NOTICE



### SAFETY INSTRUCTIONS

- Use appropriate personal protective equipment and follow safe electrical work practices (eg. NPA 70E)
- This equipment to be installed and serviced only by qualified competent electrical personnel that have appropriate training with high voltage, high energy systems
- This device is to be installed in accordance with the prevailing local and National Electric Codes such as National Electric Code (NEC) in the USA or Canadian Electric Code in Canada which governs the requirements for electrical wiring and protection

**Failure to observe and follow these installation instructions and procedures could result in serious injury or even death**

### RECEIVING

The *Cyberhawk-300* is one-piece device and the *Cyberhawk-MPC* comprises two pieces, a *Cyberhawk-300* and a STEP unit (Surge Protection Device). CTs and Interface terminals may also be included in the shipment if ordered. Unpack and inspect equipment for damage that might have occurred during shipment. Also check the packing list to ensure all the equipment is accounted for (note accessories may be shipped in separate packages).

Claims for damages should be made to the carrier immediately and also notify Powersmiths International of the details. Claims for shortages should be made to Powersmiths International at the earliest opportunity.

### HANDLING

The units weigh about 50 lbs (~ 23kg) and may require two persons to handle comfortably. When moving the equipment, always place the device in such a way to protect the Display and avoid rough surfaces that may mar or scratch the surface of the case.

### STORAGE

No special precautions need be taken in storing this device other that it should be protected from moisture or excessive humidity. Storage temperatures should not exceed the limits of  $-25\text{ }^{\circ}\text{C}$  to  $+60\text{ }^{\circ}\text{C}$

### INSTALLATION GUIDELINES

***The equipment must be installed in accordance with the prevailing local and National Electric Codes such as National Electric Code (NEC) in the USA or Canadian Electric Code in Canada, which governs the requirements for electrical wiring and protection. These requirements will include, but not limited to:***

- Branch circuit protection devices for connection to the voltage bus(es) (not supplied by Powersmiths)
- Use of an appropriate and approved Current Transformer (CT) for installation on the current carrying buses (available from Powersmiths on separate order only)
- Separation of primary (voltage sensing) and secondary wiring (CT outputs, auxiliary circuits, etc.)

*Note: This device is not intended as a utility meter or for use ahead of branch-circuit protection*

The following points should be considered in choosing a location:

- Environmental rating (Type 1 is for dry protected environments; contact factory for higher environmental ratings)
- Accessibility including clearance for the door swing
- Location relative to associated Breakers, Disconnects and CTs
- Viewing height for display

## OVERVIEW

The *Cyberhawk-300/MPC* monitors electrical networks and provides data on Voltage, Current, Power, Energy and Power Quality with event recording, alarming and control functions that operate based on user programming. The unit is supplied in two voltage ranges and with up to three 3-phase measurement Ports depending on the configuration ordered/supplied and is UL/CUL Listed to UL916/ C22.2 No. 1010.1-92.

Auxiliary Inputs and Outputs are available for ancillary functions the installation of which is described in the relevant sections of this document with full operational description described in the user manual. It is configurable for a range of system configurations (see System Installation Diagrams). A single line diagram illustrating a basic system hookup is illustrated opposite.

User setup programming for operational characteristics such as Bus Voltages, Interfaces (PTs and CTs), Event Alarms, Data Logs and protective functions are described in the operational manual.

The unit also incorporates a built in WEB server which provides for remote user access to all system data, Event Logs and data logs and also facilitates setup using one of Powersmiths' propriety setup software tools.

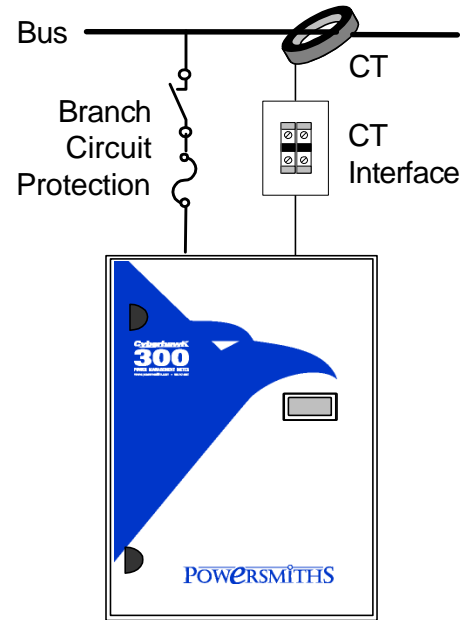

## USER SUPPLIED HARDWARE

In addition to the *Cyberhawk-300/MPC*, the following user supplied hardware will be required to complete installation:

- Branch circuit protection must be provided for bus (voltage feed) connections, either Fused Disconnects or Breakers, rated 15 Amps or less with an interrupt capacity rating to match bus short circuit rating. Breaker or fuse disconnect must be 3-pole handle tied for 3-phase, 2-pole handle tied for split-phase or 1-pole for single-phase applications.
- Primary Circuit Wires - UL Listed 600V min. with 75°C minimum temperature Copper conductors 14 – 10 gauge with branch circuit protection
- CT Secondary Circuit or Secondary Circuit - UL Listed 600V min. with 75°C minimum temperature Copper conductors 16 – 10 gauge.
- Ethernet cabling must meet the following requirements: 150Volts minimum, 75°C minimum temperature rating, Cat 3 minimum, RJ45 Plug
- CTs for sensing bus currents that have been evaluated for use with this instrument:
  - INSTRUMENT TRANSFORMERS INC, DIV OF GE MULTILIN. Models 2DARL Series, 5DARL Series, 6ARL Series, 7ARL Series, 8RL Series, 19RL Series, 550L Series, 500L Series, 600L Series, 601L Series, rated min. 600 V. Provided with min. 24 in. leads with min. 1/32 in. insulation, rated minimum 600V, and minimum of 105°C.

CTs sizing is based on the Bus current and the physical dimensions of the bus; refer to table below:

### CT Selection Table

Parameter	Requirement
<b>Primary CT Rating (current)</b>	Equal to current rating of bus or Bus Power Protection Device
<b>Primary Voltage Rating</b>	600V min.
<b>Secondary Current</b>	5 Amps at nominal current rating
<b>Burden</b>	3 VA minimum
<b>Ratio</b>	Nominal Primary Current: 5 (eg: 1000:5)
<b>Window</b>	Sized for Bus dimensions
<b>UL Listed</b>	ANSI/IEEE C57.13
<b>UL746 Compliance</b>	UL746C: Standard for Polymeric Materials
<b>Secondary Terminations</b>	Wire Leads with minimum specifications as follows: Voltage: 600V minimum Temperature: 105 °C Insulation: 1/32 inch Wire Lead Length: 24" minimum
<b>CTs* investigated for use with this instrument</b>	Manufacturer: (GE) Instrument Transformers Donut Models: 2DARL-xxx; 5DARL-xxx; 6ARL-xxx; 7ARL-xxx; 8RL-xxx; 19RL-xxx; Rectangular Models: 550-L-yyy x zzz-xxx Split-core Models: 500-L-xxx; 600-L-xxx; 601-L-xxx Note: xxx denotes ratio (e.g. - 501 is 500:5) yyy and zzz denotes window dimensions

\*Note: These CTs are listed to UL ANSI/IEEE C57.13 and additionally comply with the requirements of UL916 with regard UL746 for polymeric material requirements and secondary lead termination as specified above

#### OPTIONAL HARDWARE

The following hardware may be required based on the requirements of the installation:

- CT Interface Terminal Blocks  
*Note: Facilitates CT termination and service (available from Powersmiths; see description below)*
- System Breaker(s) fitted with a shunt trip coil for protection function (if applied)
- Contactor(s) for control functions
- Type 'A' Thermistors for Temperature sensing (available from Powersmiths)
- Surge Protection Devices (by Powersmiths or others)

#### POWERSMITHS CT INTERFACE BOX (option)

The Powersmiths CT Interface Box consists of a set of terminals mounted in an electrical box and provides a convenient termination point for the CT secondary leads close to the CT location. In addition it provides a means of conveniently shunting (shorting) the CT outputs to facilitate equipment service.

#### SYSTEM INSTALLATION CONFIGURATIONS

Prior to installation make a wiring diagram of the desired connections with reference to the appropriate system configuration for each measurement Port to be connected. Note that wiring type configurations and the system configuration are illustrated in this bulletin. This will determine the system voltage connections and the number of CTs required. The following system configurations are supported:

**Table of Wiring Type Configurations**

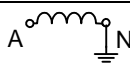
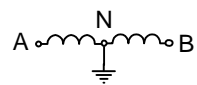
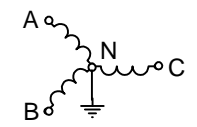
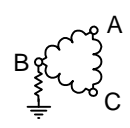
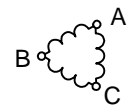
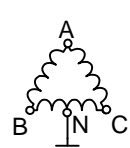
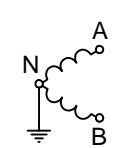
<b>System Type</b>	<b>Diagram</b>	<b>Connection</b>
Single Phase		2-wire + GND, 1 CT
Split Phase 3-Wire		3-wire + GND, 2 CT
Three Phase Wye		4-wire + GND, 3 CT
Three Phase Delta (resistance corner grounded)		3-wire + GND, 2 CT
Three Phase Delta (ungrounded)		3-wire, 2 CT
Three Phase High Leg Delta		4-wire + GND, 3 CT
Three Phase Open-Delta		3-wire + GND, 2 CT

Auxiliary connections for sensing and control and communication are detailed in the I/O connection section.

**UNIT DIMENSIONS**

Unit dimensions and mounting details are illustrated following:

*Note that the CT Interface Box illustrated is a recommended option that is used to facilitate installation and service.*

**Cyberhawk-300/MPC Outline**

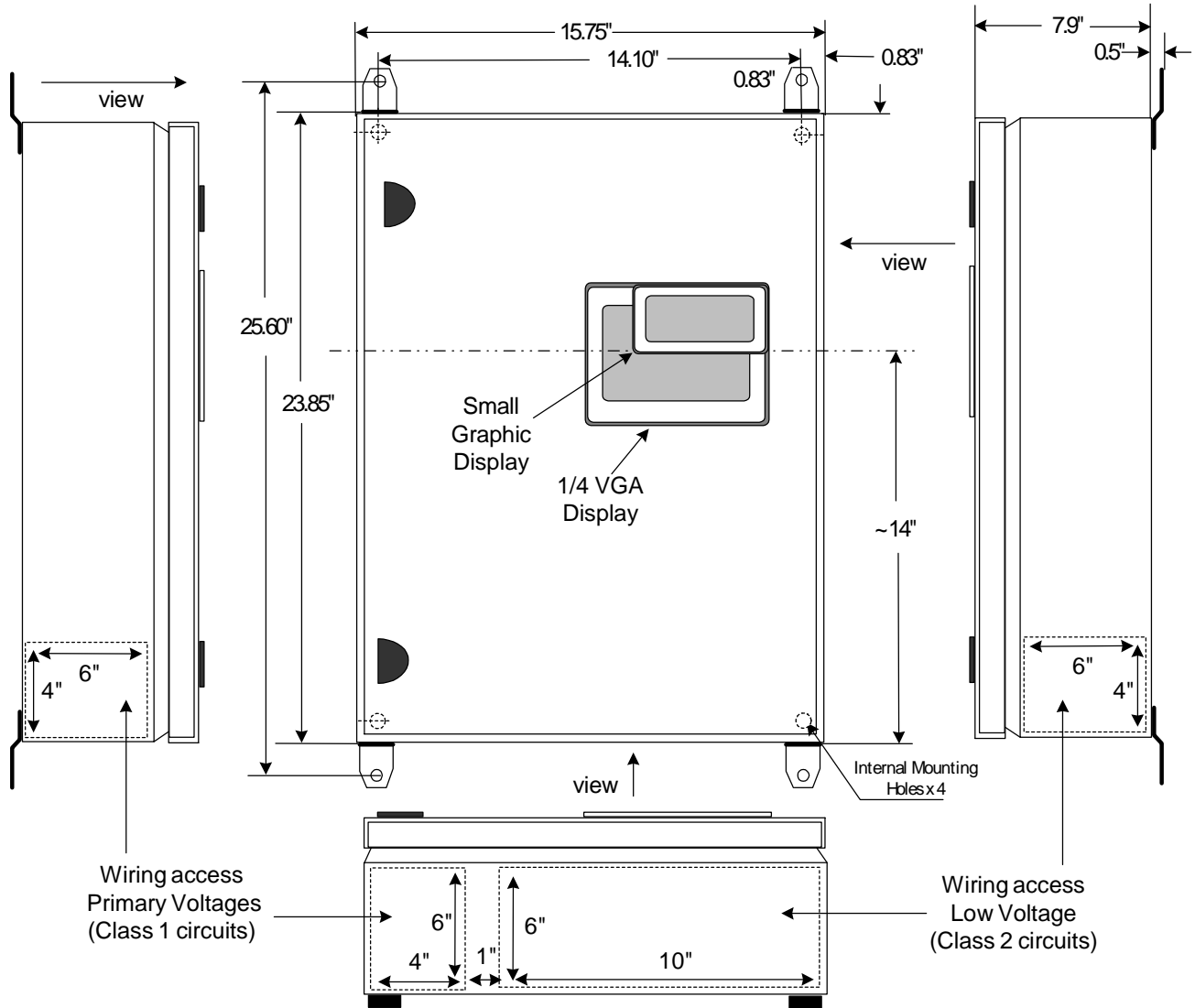

**Mounting Hardware**

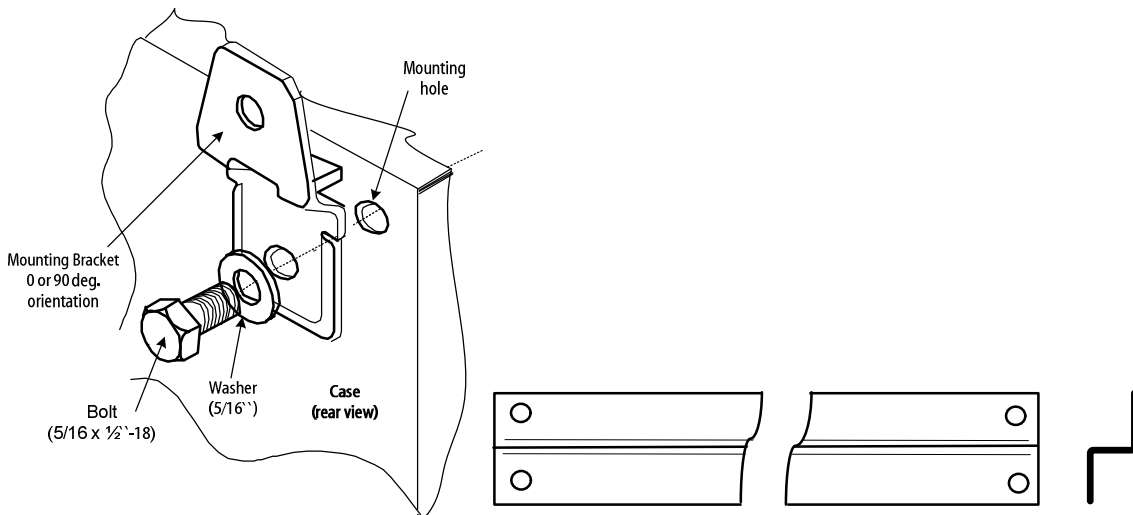

### CT Interface Box Outline

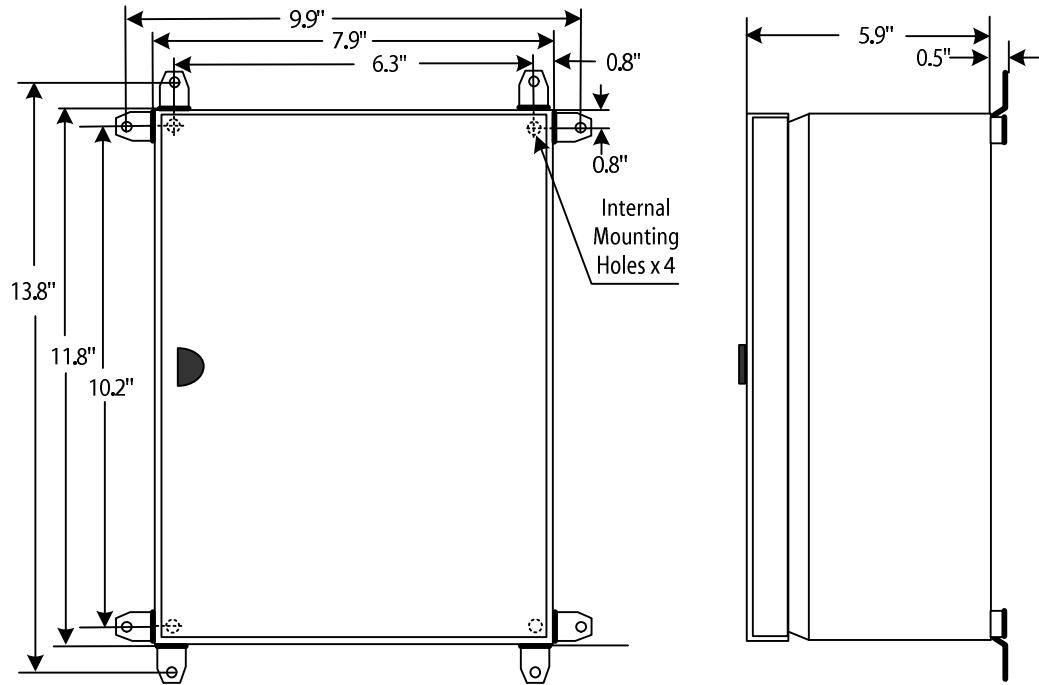

### Mounting Hardware

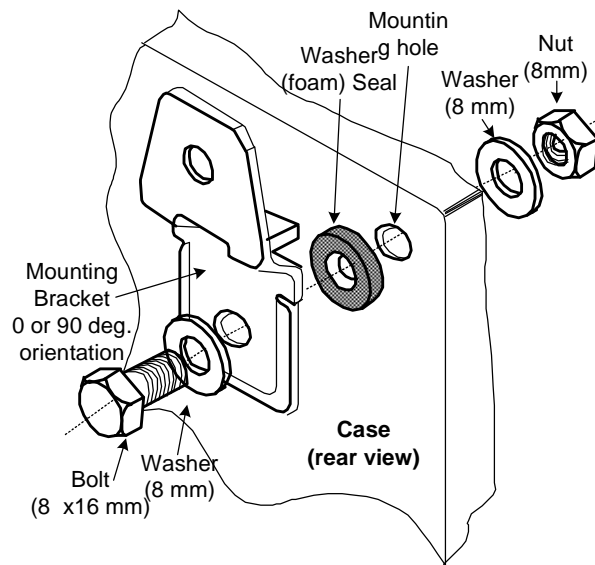

## INSTALLATION

WARNING	HAZARD OF ELECTRIC SHOCK OR ARC FLASH
 <p data-bbox="302 432 516 508"><b>Risk of Electric Shock</b></p>	<ul style="list-style-type: none"><li>▪ Open or disconnect all power sources and “Lock out” prior to any work being done on the electrical system</li><li>▪ More than one disconnect switch may be required to de-energize the equipment before servicing</li><li>▪ Open or disconnect circuit from power-distribution system (or service) of building before installing or servicing current-sensing transformers (CTs)</li><li>▪ Never leave CTs in powered circuit open circuited</li></ul>



**Caution:** *Do not assume but check that all power sources at the system connection points are off using a properly rated voltage indicating device (Multi-meter, etc)*

## MOUNTING

### Prior to Installation:

Prior to installation check the internal condition of the equipment as follows:

- Equipment Voltage rating for the application (e.g. 480/600V, 120/208V)
- Damaged or dislodged or loose components
- Loose connectors or connections
- Broken wires

### Mounting the *Cyberhawk-300/MPC*

- Attach the mounting brackets to the *Cyberhawk-300/MPC* with supplied mounting bracket hardware. One of two types may be supplied as illustrated.
- Mount the unit to the wall in the required location with ¼” hardware appropriate for the mounting surface material (Note: mounting hole is 5/16”).

### Mounting the CT Interface Box (if supplied)

- Attach the wall mounting brackets to the *CT Interface Box* with supplied mounting bracket hardware as illustrated above
- Locate and mount the unit to a wall in the required location with ¼” hardware appropriate for the mounting surface material (Note: mounting hole is 5/16”).

*Note locate the CT Interface Box to allow for direct wire connections (without splices) from the CTs to the terminals in the box.*

### Installation of Branch Circuit Protection Devices

- Install a Branch Circuit Protection Device (Fused Disconnect or Breaker) for each Bus to be monitored following the specific manufacturer’s instruction and in compliance with the relevant local and national electric codes\*.

*\*Reference: NEC 2005 Article 408 Para: 408.52*

## Installation of Current Transformers

<b>WARNING</b>  <b>Risk of Electric Shock</b>	<b>HAZARD OF ELECTRIC SHOCK OR ARC FLASH</b>  To reduce risk of electric shock, always open or disconnect circuit from power-distribution system (or service) of building before installing or servicing current-sensing transformers
------------------------------------------------------------------------------------------------------------------------------------------	---------------------------------------------------------------------------------------------------------------------------------------------------------------------------------------------------------------------------------------------

### Considerations:

CTs may be installed in Electrical Enclosures, Switchgear, Switchboards, Panel-boards or in auxiliary gutters on the current carrying bus wires under the following code requirements\*\* and considerations:

- Installation of the CTs within Switchgear, Panel-boards or Gutters shall not reduce the available space to more than 75% of its available volume\*  
*\*See NEC 2005 Article 312 Para: 312.8 and Article 366*
- CTs and the secondary wires are to be arranged away from live terminals and the CTs secured to the bus wires using a minimum of three cable ties to prevent movement of the CTs
- CT secondary wires to be secured in their desired position away from the current carrying bus
- CT Secondary wires are to be feed in a dedicated conduit installed for the purpose (not common with live bus voltage wires) to the meter or CT Interface Box (if fitted).

Note: No splices on the CT secondary wires are permitted within the enclosure where installed or in the conduit through which the secondary wires are run. Splices are only permitted as follows:

- Within the CT Interface Box or the *Cyberhawk-300/MPC*
- In a dedicated Auxiliary Gutter or Terminal box

Note: Splices must comply with the requirements of the relevant local and national electric codes See *NEC 2005 Article 110 Para: 110.14 (B)*

### Installation:

- Install each CT on the required phases of current carrying bus wires with regard to phase and polarity (see diagram opposite)  
Note that errors in CT phasing may be corrected later by simply reversing the secondary leads at their termination point.
- Secure CT secondary wires in their desired position away from the current carrying bus using cable ties
- Feed the CT Secondary wires through the dedicated conduit installed for the purpose (not common with live bus voltage wires) to the meter or CT Interface Box (if fitted)

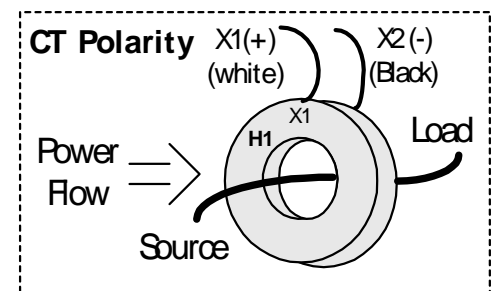

### *Cyberhawk-300/MPC* Terminal Identification

The internal terminals are identified below and are segregated into Class 1 and Class 2 partitions. Note that one (1) auxiliary is located in a segregated wiring area separate from the class 2 wiring area.

*Note that this segregation of wiring must be adhered to during installation*

## Terminal Identification and Layout

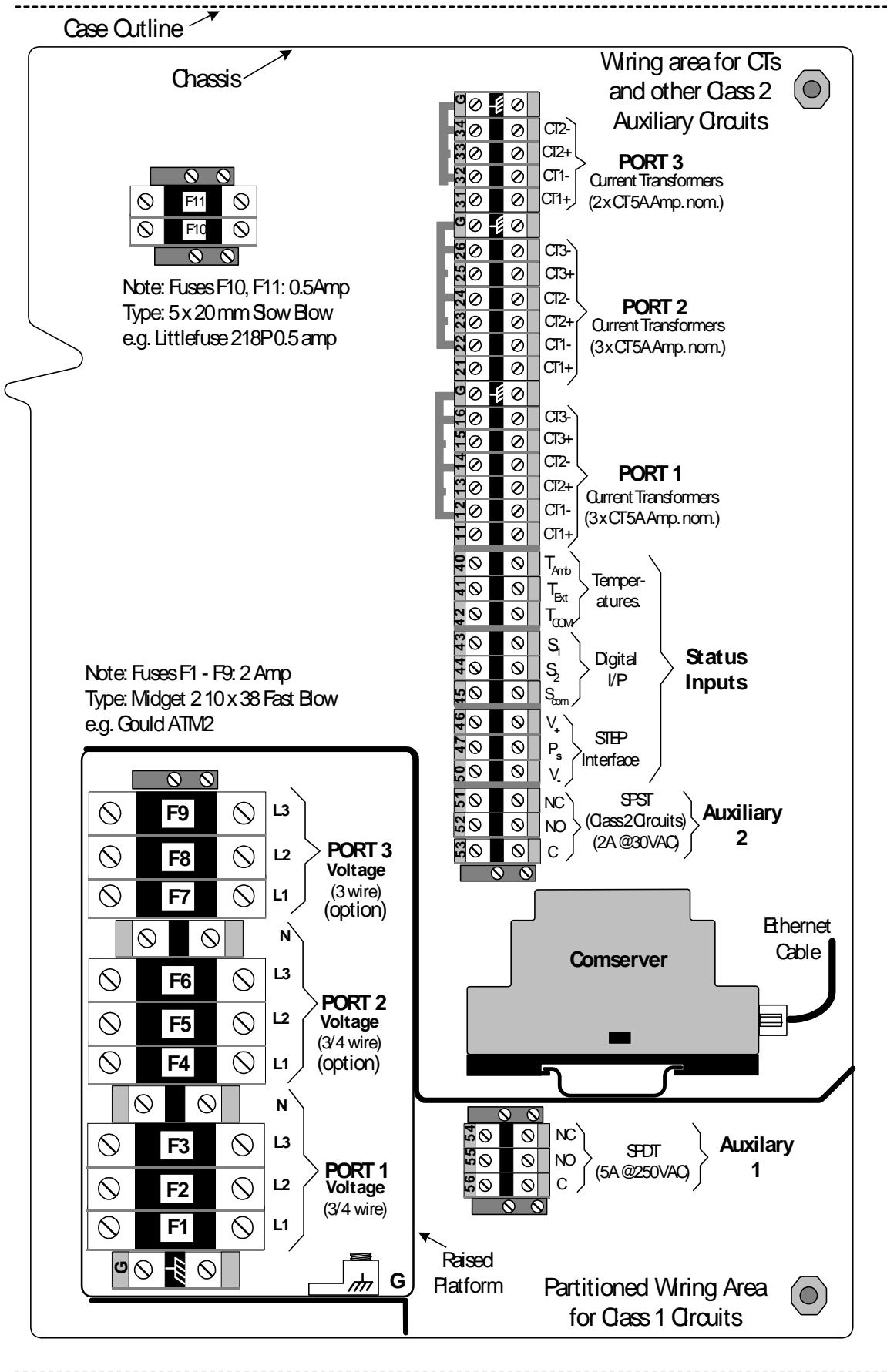

## SYSTEM WIRING

The *Cyberhawk-300/MPC* is supplied with 1, 2 or 3 Ports (order specific) that may be configured to operate on any of the listed configurations requiring a specific hookup and setup. Internal operating power is derived from Port 1; other Ports only provide sensing.

Wire the unit per the relevant local and national electric codes\* and the following instructions and with reference to the specific system diagram for the application configuration.

\* See *NEC 2005 Section 200 (Wiring and Protection)*

### Voltage Hookups:

Wire each Port Voltage Input through Branch Circuit Protection Devices\* (Breaker or Fused Disconnect) rated 15 Amp or less (5 Amps recommended) with an interrupt capacity rating to match the bus short circuit rating. This protection device, Breaker or Fuse disconnect, must be 3-pole handle ties for 3-phase or 1-pole for single phase applications.

*\*Reference: NEC 2005 Article 408 Para: 408.52*

*Notes:*

- *Wires to be copper conductors 14 – 10 gauge rated 600 Volt minimum with 75 °C minimum temperature rating*
- *Unit must have a grounded conductor wired to the ground terminal*
- *Each ungrounded connector must be ‘fused’ including the Neutral if it is not grounded*
- *This wiring must be segregated in the Class 1 wiring compartment separate from the Class 2 circuits*
- *Actual unit load is less than 100mA per phase*
- *Actual phase rotation is not critical but CTs and the voltage connection must match e.g. CT1 on L1 etc.*

### CT Hookup (through CT Interface):

Wire the CT secondaries through a dedicated conduit (as previously described) to the CT Interface box and terminate at the appropriate terminal observing polarity

Wire the CT secondaries from the other side of the CT Interface terminals to the *Cyberhawk-300/MPC* through a dedicated conduit observing polarity

*Notes:*

- *Wires to be copper conductors 18 – 10 gauge rated 600 Volt minimum with 75 °C minimum temperature rating*

### CT Hookup (direct):

Wire the CT secondaries through a dedicated conduit (as previously described) to the *Cyberhawk-300/MPC* through a dedicated conduit observing polarity

### Ethernet Cabling:

The unit is equipped with an Ethernet Port. Cabling to this Port must meet the following requirements:

- *Ethernet Cabling to be rated 150 Volt minimum with 75 °C minimum temperature rating with a RJ45 termination plug*

### System Wiring Diagrams:

The following system wiring diagrams detail the wiring for each configuration to the Port 1/2 or Port 3.

**Wiring Diagram for 1-Phase 2-wire systems to Ports 1 or 2**

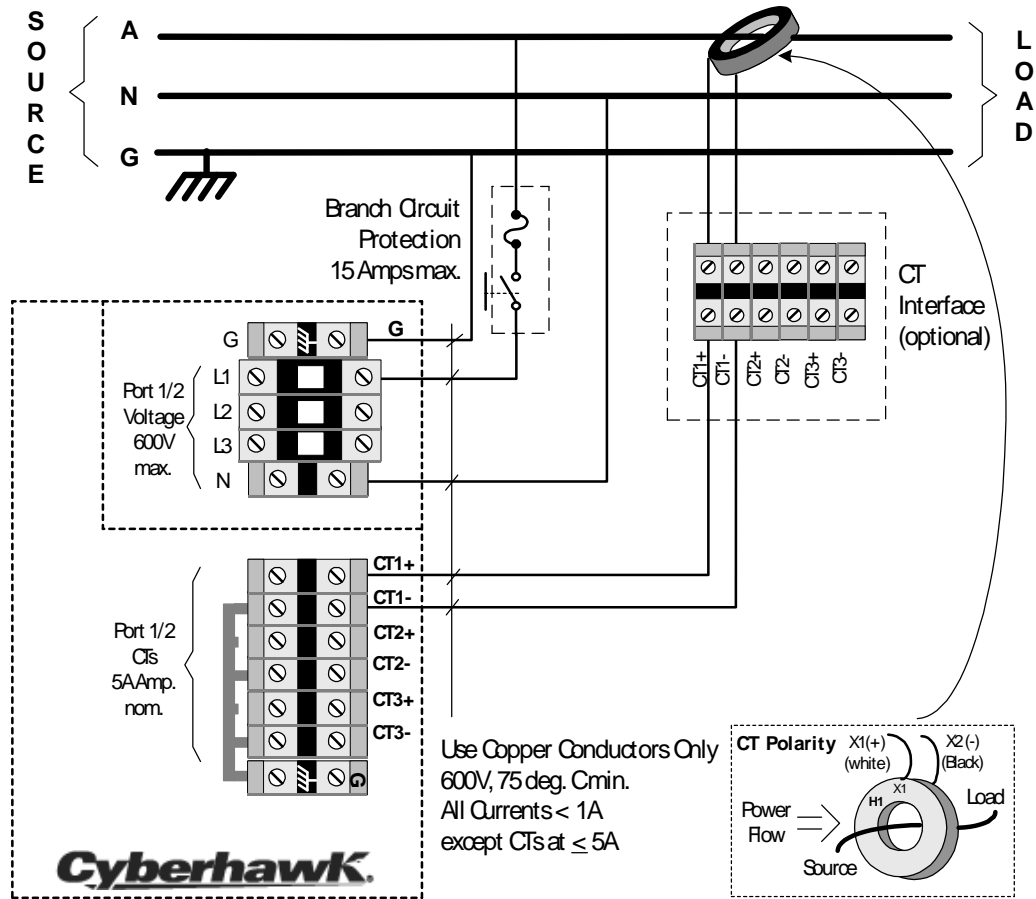

**Wiring Diagram for 1-Phase 2-wire systems to Ports 3**

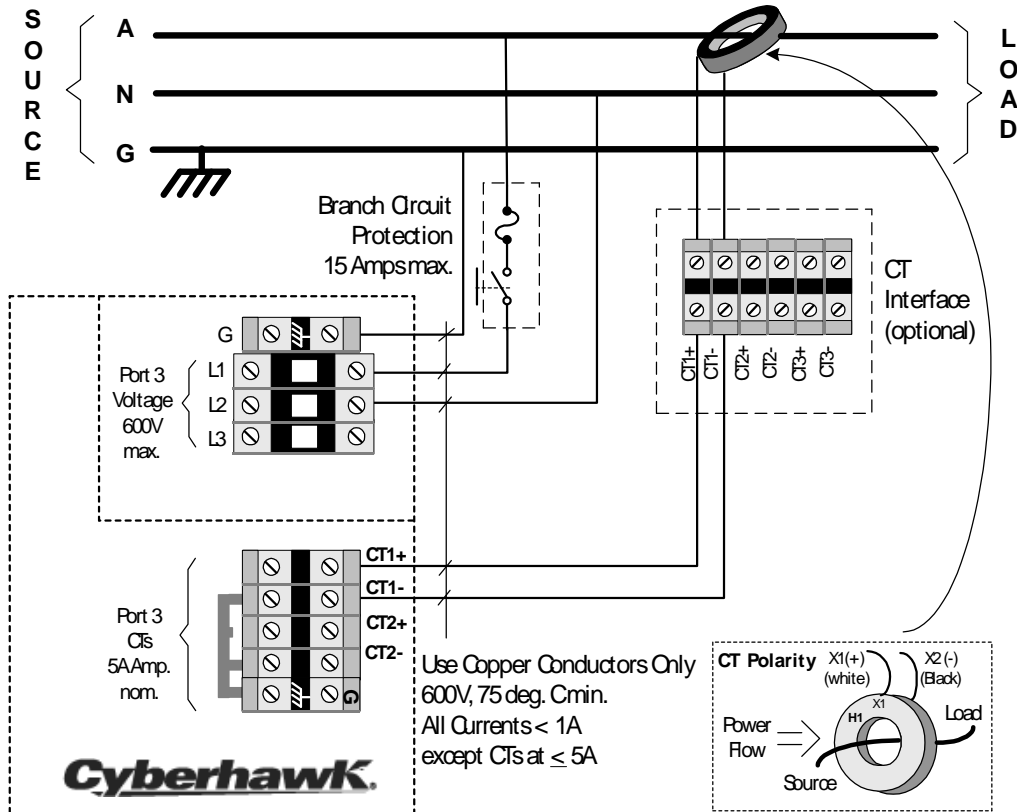

**Wiring Diagram for Split Phase 3-wire systems to Ports 1 or 2**

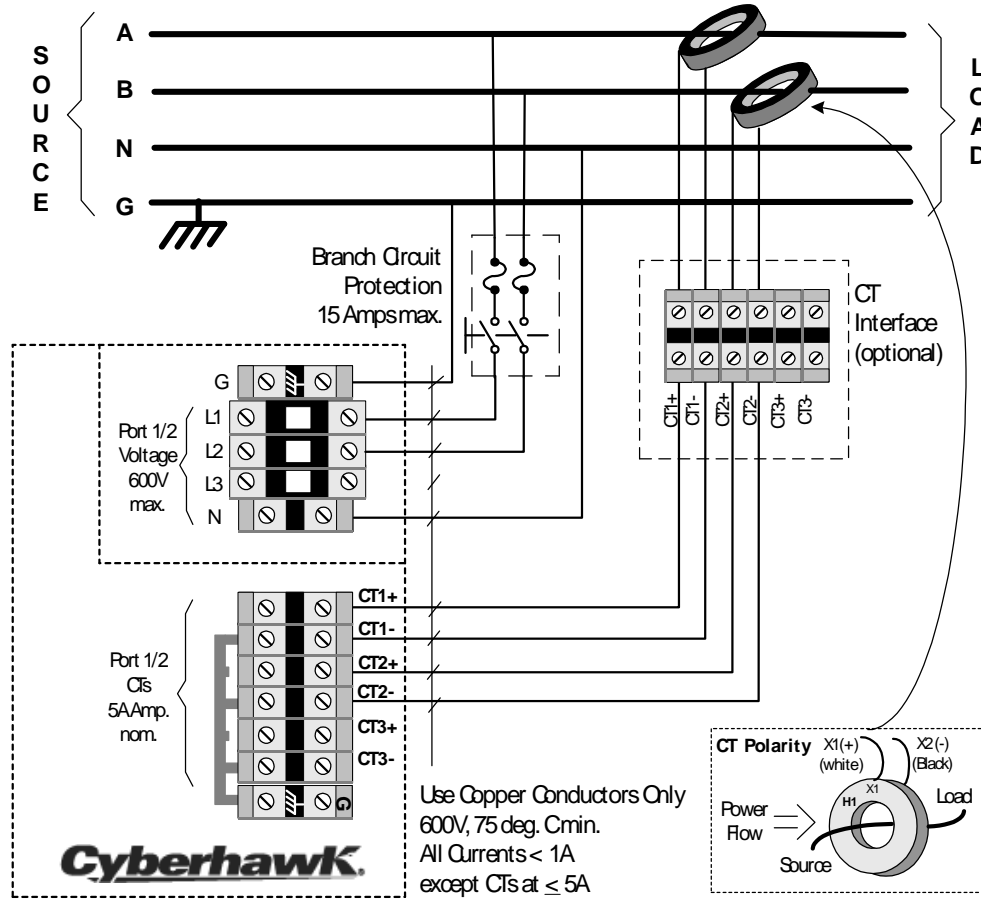

**Wiring Diagram for Split Phase 3-wire systems to Port 3**

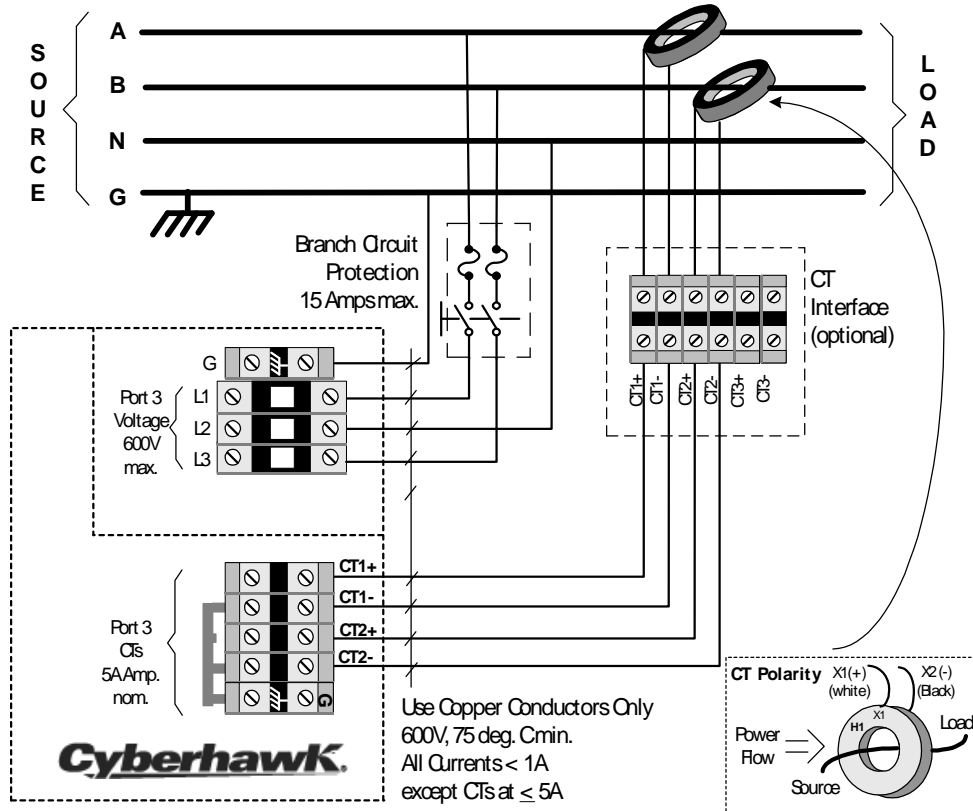

**Wiring Diagram for three phase 4-wire systems to Ports 1 or 2**

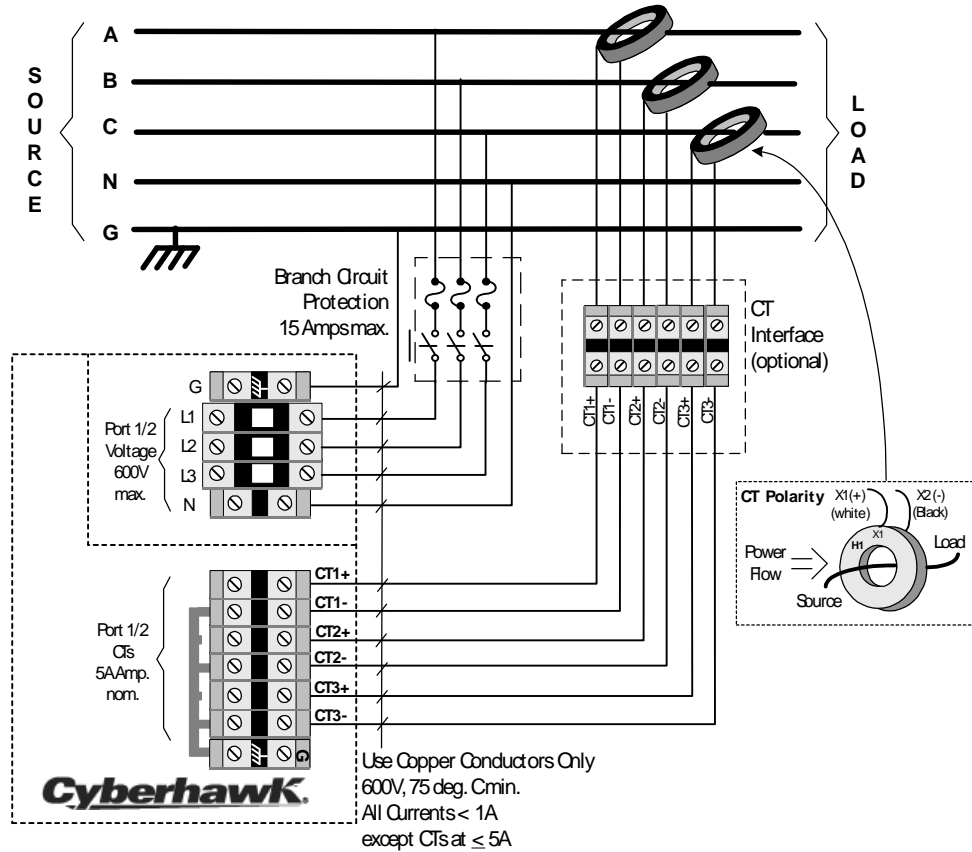

**Wiring Diagram for three phase 3-wire systems (grounded or ungrounded) to Ports 1 or 2**

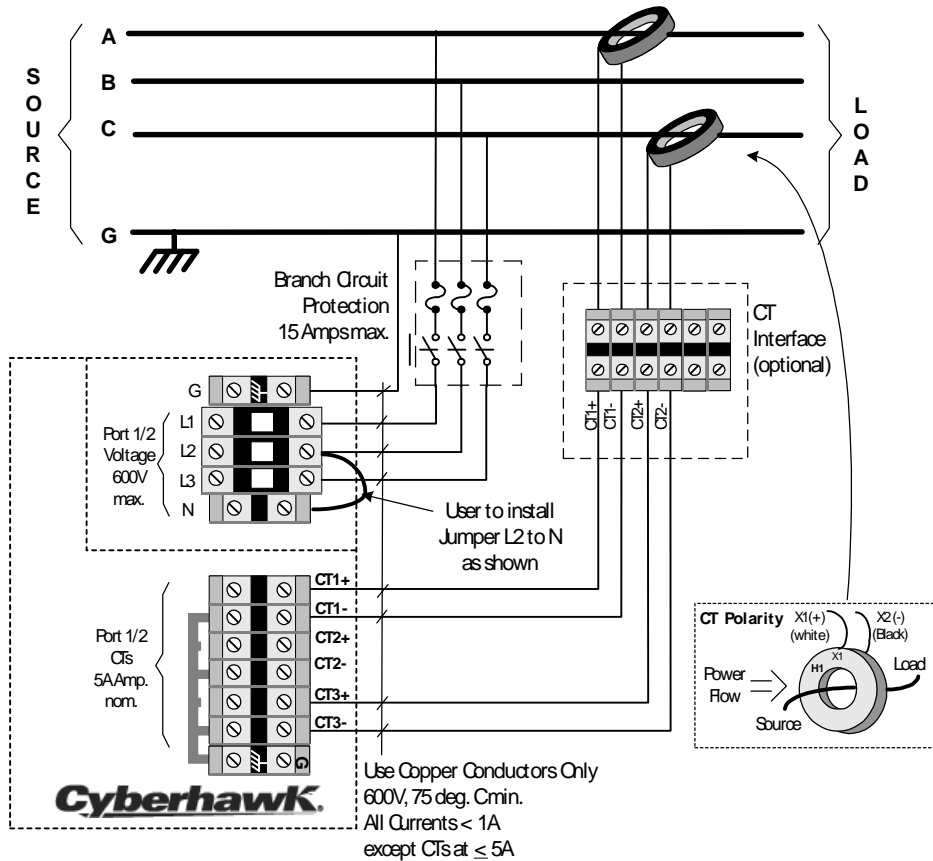

**Wiring Diagram for three phase 4-wire High Leg systems to Ports 1 or 2**

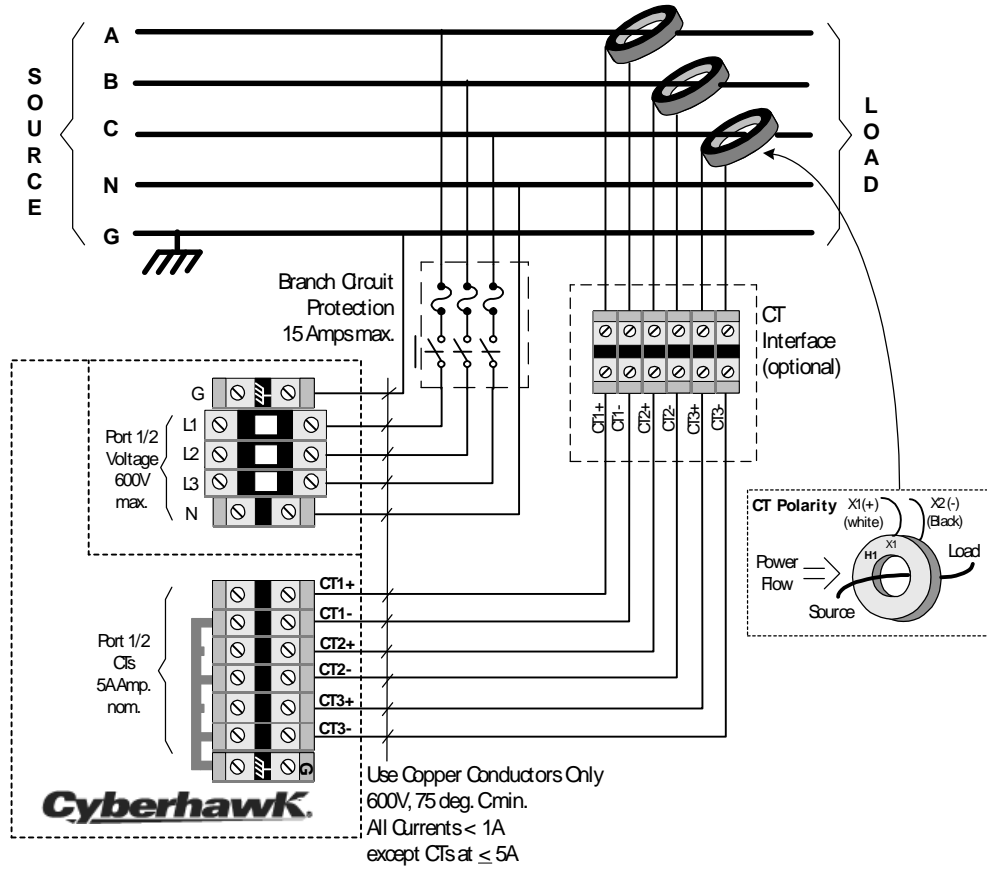

**Wiring Schematic for three phase 3-wire systems (grounded or ungrounded) to Port 3**

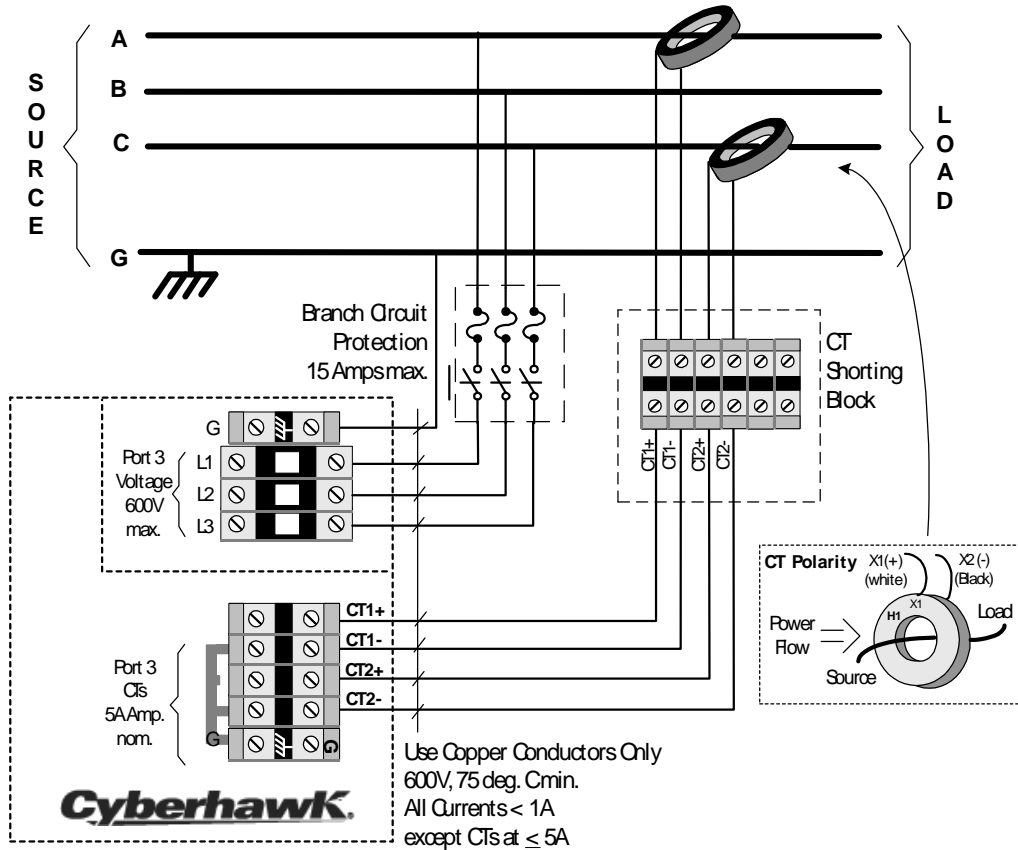

## INPUT/OUTPUT HOOKUP

The following input and output interfaces may be optionally wired per the user's requirements; refer to user manual for full operational details.

*Note the requirement to keep separate the Class 1 and Class 2 circuits in their respective compartments*

### Remote Signaling Relay (Auxiliary) 1

The Form C electro-mechanical auxiliary contacts may be used for remote signaling and control. Typical signaling applications are illustrated below with control applications following. Refer to the user manual for full setup and operational instructions.

**Table of Relay 1 Output Characteristics**

Parameter	Description	Typical Application
Type	Form C: C, NO, NC	
Connector	Compression; 12 to 18 ga. wire	
Maximum Rating	240VAC @ 5A	
Operational Rating	240VAC @ 5A	
Isolation	2,500VAC	
Location	Class 1 segregated compartment	
Response Time	½ Cycle + 2 ms to minutes (user programmable)	

### Remote Signaling Relay (Auxiliary) 2

The form C electro-mechanical auxiliary contacts may be used for remote signaling.

**Table of Relay 2 Output Characteristics**

Parameter	Description	Typical Application
Type	Form C: C, NO, NC	
Connector	Compression; 12 to 18 ga. wire	
Maximum Rating	240VAC @ 5A	
Operational Rating	30VAC/DC @ 2A	
Isolation	2,500VAC	
Location	Class 2 segregated compartment	
Response Time	½ Cycle + 2 ms to minutes (user programmable)	

## Remote Control Functions with Relay (Auxiliary) 1

The control function is normally used to trip or control another device for such conditions as over-voltage, swells, sags or single phasing. The following diagrams illustrate some of the typical applications subject to the limitation previously described in the Relay Output Characteristic tables above.

### Shunt Trip of Load Breaker using 120VAC Source

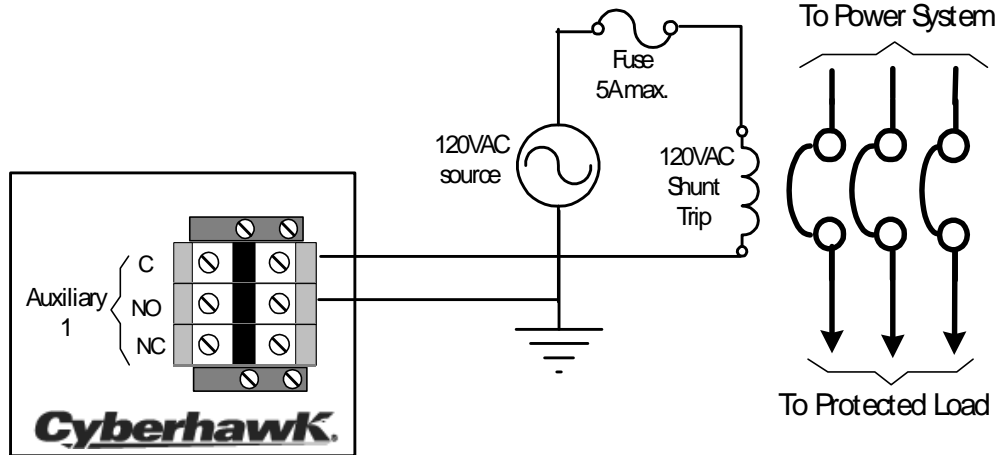

### Load Control using 120VAC Source

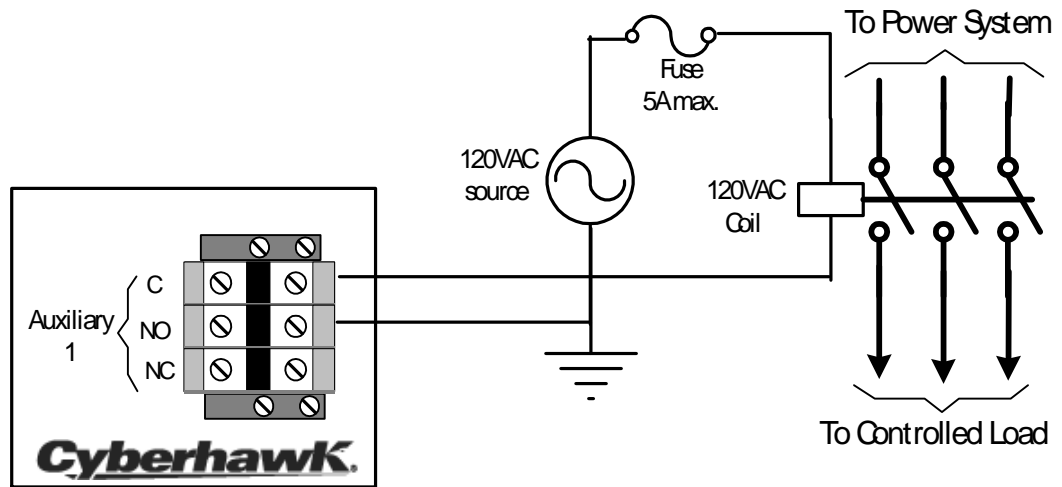

## Remote Control Functions with Relay (Auxiliary) 2

The control function is normally used to trip or control another device for such conditions as over-voltage, swells, sags or single phasing. The following diagrams illustrate some of the typical applications subject to the limitation previously described in the Relay Output Characteristic tables above.

### Shunt Trip of Load Breaker using 24VDC Internal Source

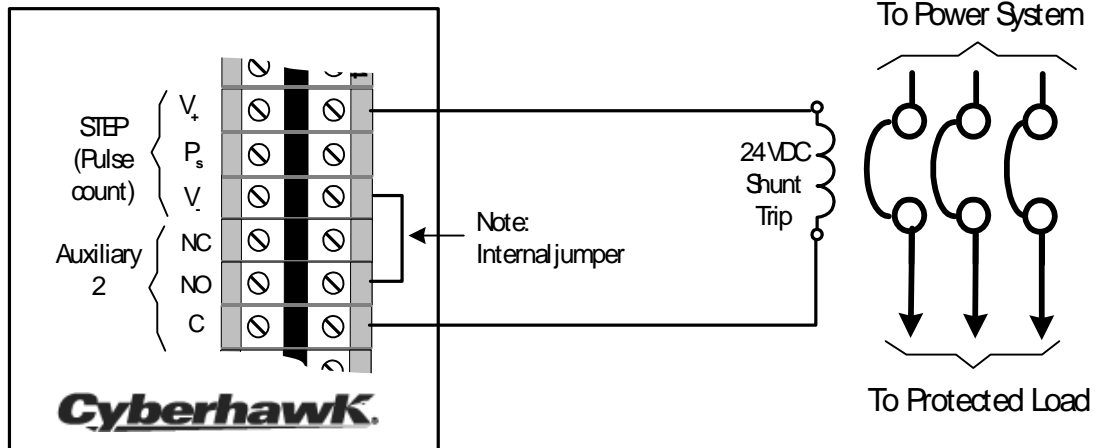

### Equipment Control using Signaling Contact

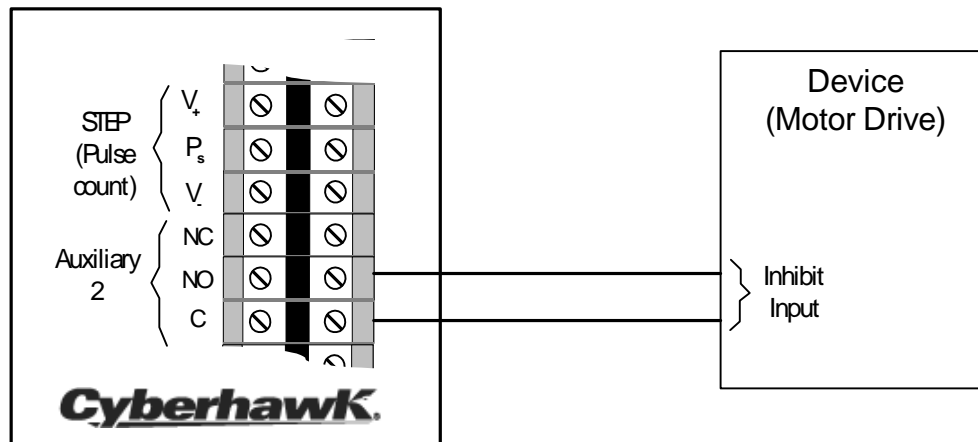

## Digital Inputs

The digital inputs are used to sense the state of external devices via non-potential signaling contacts.

**Table of Digital Input Characteristics**

Parameter	Description	Typical Application
Input	Non-Potential 10mA max.	
Type	NO or NC (user programmable)	
Connector	Compression; #12 to 18 ga. wire	
Excitation	Self Excited 24VDC	
Location	Class 2 segregated compartment	
Naming	User Defined	
Function	User programmable	
Response Time	1ms to minutes (user programmable)	

## Temperature Inputs

The Temperature inputs are used to sense air temperatures in selected locations.

**Table of Temperature Input Characteristics**

Parameter	Description	Typical Application
Sensor	Type "A" Thermistor	
Inputs	2 (1 sensor included)	
Reference	5 VDC	
Connector	Compression; 12 to 18 ga. wire	
Temp. Range	-20°C - 220°C	
Function	Display and alarming	
Location	Class 2 segregated compartment	
Response Time	~ 1 min.	

## Analog Inputs (options)

The analog inputs when fitted are used to sense the voltage level or current loops of Class 2 external devices. Consult user manual for details.

### Transient Currents (option)

The Transient Current sensor is intended to sense transient currents flowing in an external SPD. The *Cyberhawk-300* records the transient event with a date/time stamp.

Inputs	2 (sensors included)
Threshold	50 A – 500A (factory preset)
Connector	Compression; 12 to 18 ga. wire
Function	Record Transient Event
Location	Class 2 segregated compartment
Polarity	Bipolar (direction insensitive)
Response Time	< 1 us

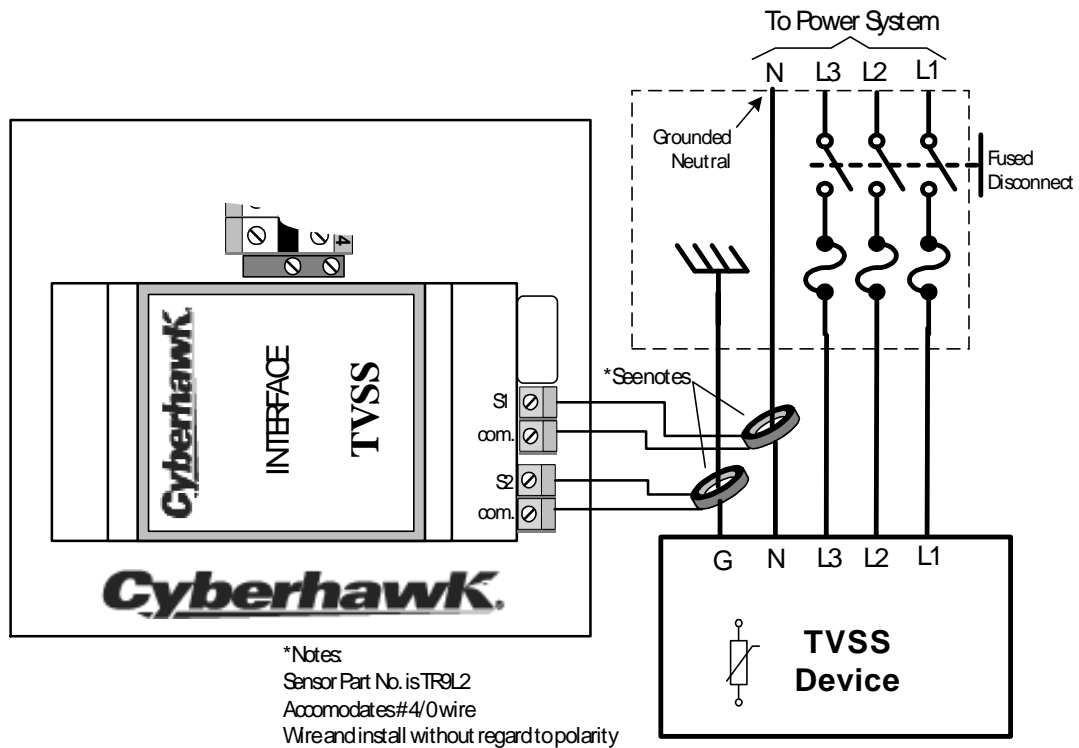

## Cyberhawk-MPC to STEP Interface

Interface connections between Cyberhawk-MPC and STEP provide for monitoring STEP "Health" status and transient activity. Hookup interface connections are shown below.

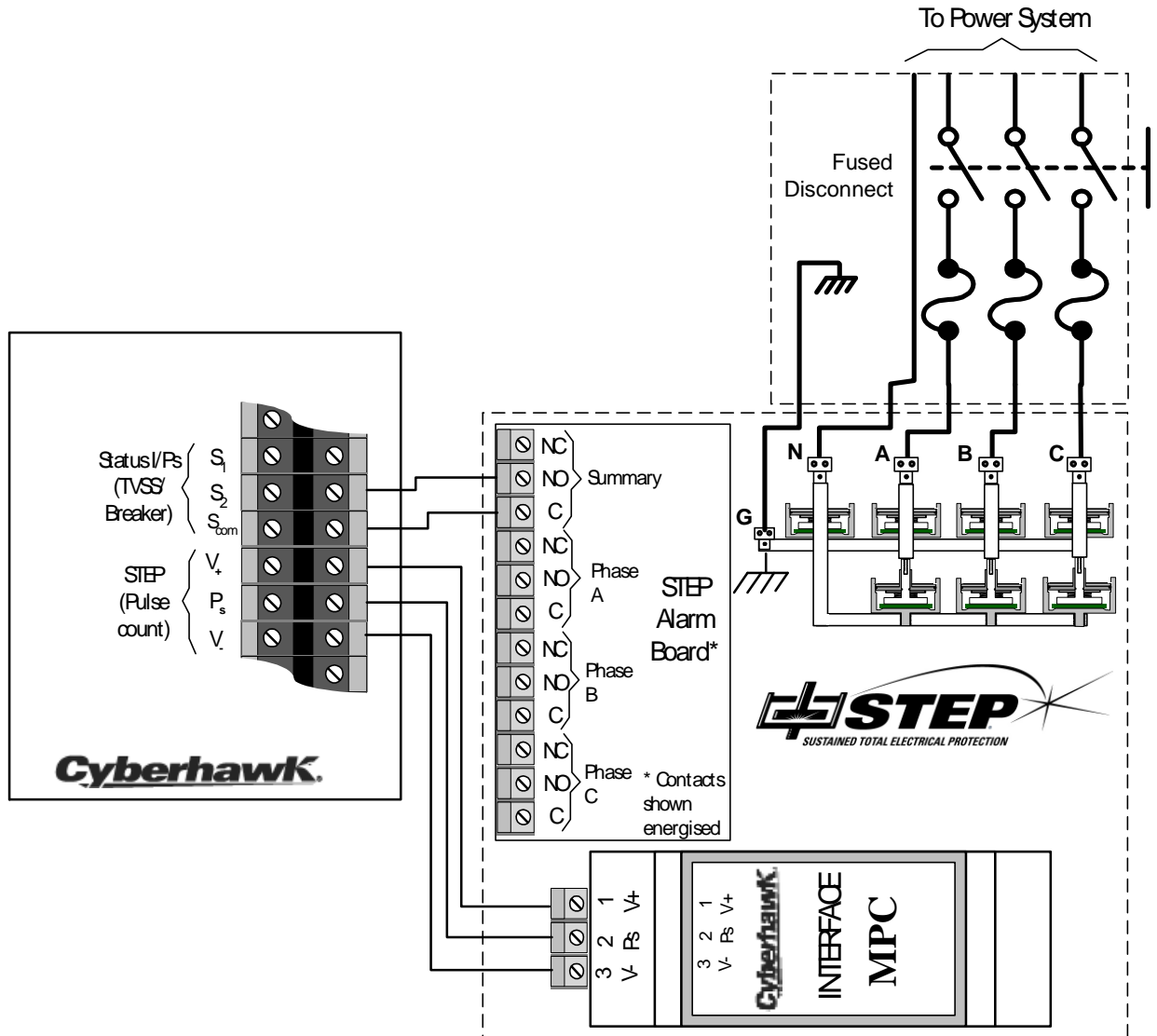

## COMMUNICATION

The *Cyberhawk-300/MPC* is equipped to support remote communication over RS485 or Ethernet. However, it only supports one external communication port (RS485 or Ethernet) at a time. To facilitate use of the RS485 (instead of the Ethernet port) unplug the RJ11 connector from the Cyberhawk Comserver (see diagram below under Ethernet). The communication port access is located vertically on the terminal compartment divider and may be one of two types as shown below.

### Communication Ports

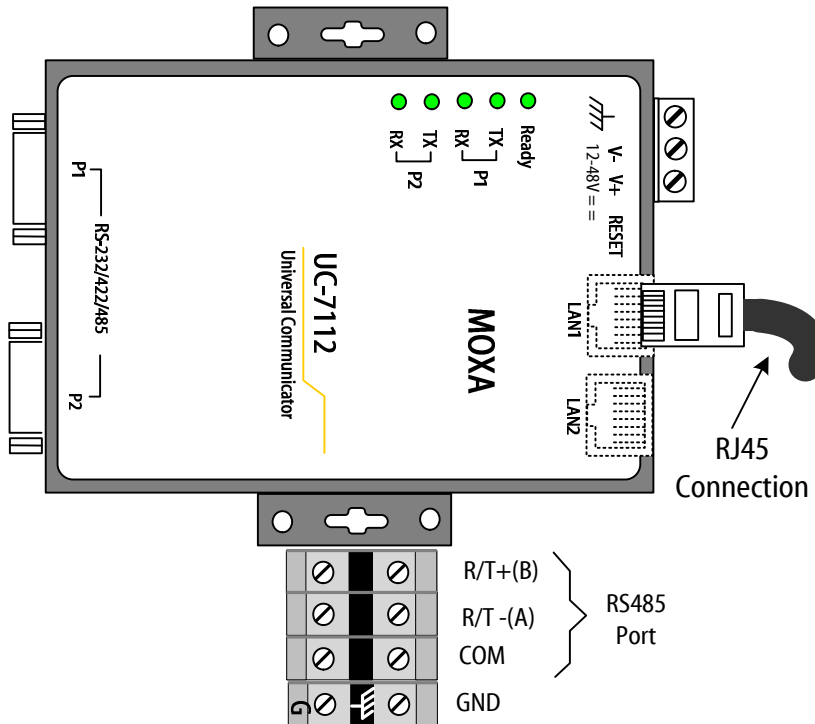
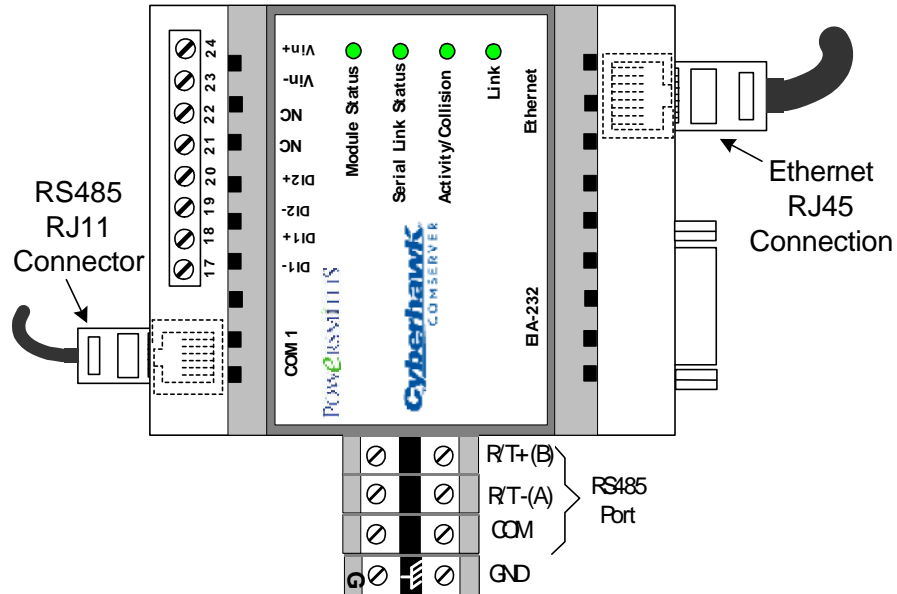

### RS485 Port

Wire the RS485 port to the RS485 network using a low capacitance shielded twisted pair (e.g. Belden 9841 or equivalent). Up to 32 devices may be daisy chained with each end of the network terminated with a 120 ohm resistor.

**Table of RS485 Network Characteristics**

Parameter	Description	Typical RS485 Network Connection
Connections	Com (Shield) R/T - (A) R/ T + (B)	
Configuration	Slave	
Baud Rate	1,200 2,400 4,800 9,600 19,200	
Max. Range	1,200 m	
Connector	Compression; 12 to 24 ga. wire	
Wiring (typical)	300V 75°C #18 – 24 ga. Z = 120 ohms	
Termination	120 ohms (jumper selected)	
Location	Class 2 segregated compartment	
Protocol	Modbus RTU	

### Ethernet Port

The Cyberhawk-300MPC is equipped with an Ethernet Network communication port. Physically the port is connected using a standard Ethernet patch cable fitted with a RJ45 plug. Connection can be to a network or to a PC using a cross over patch cable that may be required prior to connection to the network; refer to the Powersmiths Comserver user manual for setup instructions

**Table of Ethernet Port Characteristics**

Parameter	Description
Bit rate	10/100 BaseT
Connection	RJ45
Isolation	1,500V
Location	Class 2 segregated compartment
Protocols	TCP/IP, HTTP, Modbus TCP

## OPERATIONAL CHECKS

CAUTION	RISK OF ELECTRIC SHOCK
	<ul style="list-style-type: none"><li>▪ Replace all equipment covers (or doors) prior to powering on</li><li>▪ Do not attempt any internal service of the power meter</li><li>▪ Do not touch any electrical terminals; CT inputs may generate dangerous voltages if not properly terminated</li><li>▪ Refer all servicing only to by qualified competent electrical personnel that have appropriate training with high voltage, high energy systems</li><li>▪ Open or disconnect circuit from power-distribution system (or service) of building before any service (e.g. wiring corrections) is attempted</li></ul>

Please refer to the manual for full setup and operating instructions

- Open CT Shorting Links (if any were installed)
- Close all equipment covers
- Power on system Bus
- Observe that the display on the *Cyberhawk-300/MPC* lights up in a few seconds
- Setup the *Cyberhawk-300/MPC* following instructions given in the user manuals which may be setup locally at the screen or remotely over one of the wired communication ports